



Logomatic Series 200

Manual back-up label printer

/ Industrial design

/ Network or stand-alone

Logomatic Series 200

Off-line/back-up printer for up to A4 label formats

Models

- / 210: for labels to 110 mm width
- / 215: for labels to 156 mm width
- / 220: for labels to 210 mm width

Printing characteristics

- / Thermal direct or thermal transfer printing method for labels up to A4
- / Print resolution: 300 dpi or 203 dpi

Label material

- / Running length: up to 150 m
- / Outer diameter: 200 mm
- / Label core: 50/76 mm

Operation

- / 5" touchscreen function for numeric entry
- / Optional: HMI 10" colour display
 - with touchscreen function
 - with alphanumeric entry
 - multilingual user interface
 - current label display

Interfaces

- / Integrated Ethernet port
- / High-speed RS-232 (optional: RS-422)

Standard functions

- / Standard barcodes and 2D codes
- / Logos and graphics
- / Internal article database
- / Integrated real-time clock
- / Individually programmable counters
- / Fault diagnosis
- / Maintenance interval display

Ambient conditions

- / Operating temperature: 5 °C – 37 °C
- / Humidity: 20 % – 85 % relative, non-condensing
- / Electrical connection: 100 – 240 Volt; 50 – 60 Hz

Certificates

- / CE certified (EU)
- / Optional: TR/EAC (RU)
- / Optional: SASO (SA)
- / Optional: UL 508 (US)

Additional options

- / RFID
- / Internal rewinder for backing paper
- / Internal rewinder for printed labels
- / External rewinder for printed labels
- / Cutter
- / Enclosure in stainless steel and special colours available
- / Software:
 - Middleware package: LogoSoft
 - Label design: LEAP Express
 - Management: LogoRemote
 - Real-time connectivity
 - Stand-alone

Spare parts/maintenance

- / Full spare parts available worldwide
- / Proven life expectancy of 10 years +
- / Bespoke service support and preventive maintenance
- / Telephone support

Models 210/215/220

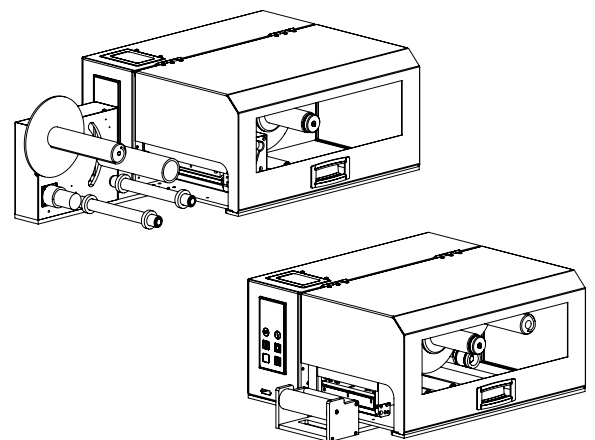
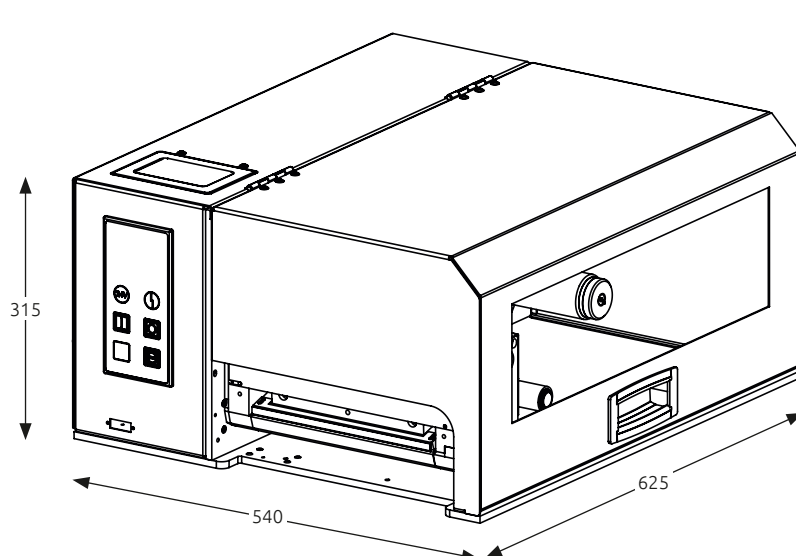

All dimensions in mm. Subject to technical changes.