

(00) 340382230000000009



Logomatic Series 230

Manual labelling system
for the paper industry up to A3

**Manual
label printer**
• Industrial design
• Network or stand-alone



Models

- ✓ 230: for labels to 300 mm width

Printing characteristics

- ✓ Thermal direct printing method for labels up to A3
- ✓ Print resolution: 203 dpi

Label material

- ✓ 150 m standard running length
- ✓ Outer diameter: 200 mm
- ✓ Label core: 76/152 mm

Operation

- ✓ NEK touchscreen for numeric entry
- ✓ Optional: TDI 10" colour display
 - with touchscreen function
 - with alphanumeric entry
 - multilingual user interface
 - current label display

Interfaces

- ✓ Integrated Ethernet port
- ✓ High-speed RS-232 (optional: RS-422)

Standard functions

- ✓ Standard barcodes and 2D codes
- ✓ Logos and graphics
- ✓ Internal article database
- ✓ Integrated real-time clock
- ✓ Individually programmable counters
- ✓ Fault diagnosis
- ✓ Maintenance interval display

Ambient conditions

- ✓ Operating temperature: 5 °C – 37 °C
- ✓ Humidity: 20 % – 85 % relative, non-condensing
- ✓ Electrical connection: 88 – 264 Volt; 43 – 67 Hz

Software

- ✓ Middleware package: LogoSoft
- ✓ Label design: LEAP Express
- ✓ Management software: LogoRemote
- ✓ Real-time connectivity
- ✓ Stand-alone

Additional options

- ✓ RFID
- ✓ Form feed folded label materials
- ✓ Enclosure in stainless steel and special colours available

Certificates

- ✓ CE certified (EU)
- ✓ Optional: TR/EAC (RU)
- ✓ Optional: SASO (SA)
- ✓ Optional: UL 508 (US)

Spare parts/maintenance

- ✓ Full spare parts available worldwide
- ✓ Proven life expectancy of 10 years +
- ✓ Bespoke service support and preventive maintenance
- ✓ Telephone support

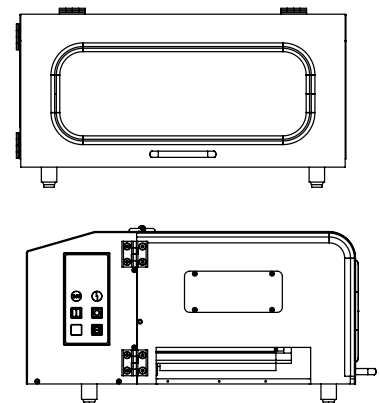
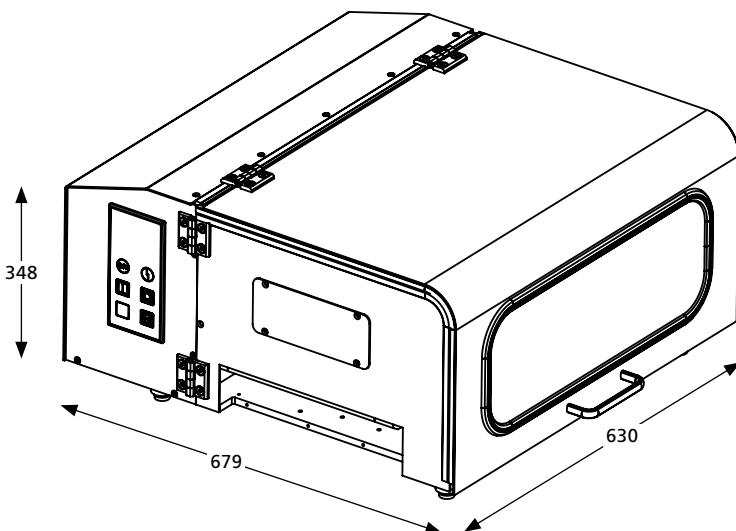

Logopak Systeme GmbH & Co. KG
Dorfstraße 40 · D-24628 Hartenholm

www.Logopak.com